

April 2007

## Description

The TPZ Programmable PROFIBUS PA Temperature Transmitter saves wire and installation costs by allowing up to 32 field devices (126 with repeaters) to be networked onto one, low cost PROFIBUS PA segment.

The loop-powered (2-wire) TPZ offers dozens of input, output and operation choices. It sets up from the control room over segment wiring using a standard PROFIBUS PA configuration tool, or from a PC using our FREE Intelligent PC Configuration Software, to handle 14 RTD types, 9 thermocouple types, as well as direct millivolt and resistance/potentiometer inputs. It converts the input to a PROFIBUS PA two-way digital communication protocol ready for interface with an AMS, DCS and other computer-based SCADA systems.

### Easy-to-Order Temperature Assemblies

One simple model number is all it takes to order our complete temperature assemblies. They include your choice of general location or hazardous area connection head, RTD or T/C sensors, thermowell and process connection.

**Figure 1.** Universal, programmable input with PROFIBUS PA digital protocol communications.

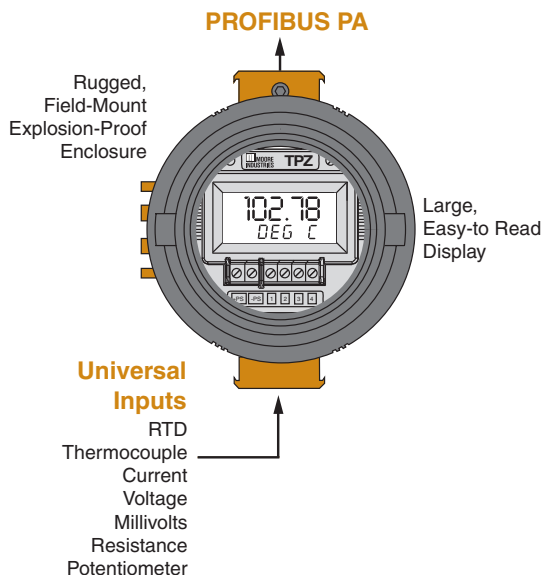

### Certifications

**CE** CE Conformant—EMC Directive 89/336/EEC  
EN 61326

\*All product names are trademarks of their respective companies.



*Available in a variety of mounting styles, the TPZ installs on a pipe or surface in the field, or on a DIN-rail and relay track in a multi-unit enclosure or cabinet.*

## Features

- **Industry-standard PROFIBUS PA communication.** Featuring a bus connection in accordance with IEC 61158-2 and EN 50170, part 4, the TPZ can be installed in the same segment with all standard PROFIBUS PA devices.
- **Exceptional measurement accuracy.** 20-bit input resolution delivers precise, industry-leading measurements.
- **Easy-to-read, customizable local display.** The large display features alphanumeric characters that can be read easily in the field. It can be customized to display the process variable or the output in user-selectable engineering units.
- **Delivers valuable diagnostic information.** Standard PROFIBUS diagnostics provide indication of unwanted process and transmitter conditions.
- **Remote configuration and diagnostics.** The ideal universal plant standard, the TPZ offers versatile input, output and operation choices, and still can be configured and troubleshooted quickly over the segment, from the control room.
- **Long term stability.** Provides up to 5 years between scheduled calibrations.
- **Advanced RFI/EMI protection and ambient temperature compensation.** Guard against environmental factors that can quickly degrade measurement accuracy.

# TPZ

## Programmable PROFIBUS PA Temperature Transmitter

### Multidrop Networks Save Wiring Costs

Acting as Slave devices within a PROFIBUS PA network, up to 32 (126 with repeaters) TPZ transmitters connect in a PROFIBUS PA (Figure 2) segment. This means you can save time and money by using a single twisted pair, instead of individual loops, to transmit information from multiple devices.

### Set Up from a DCS, Asset Management System (AMS) or PC

The TPZ can be remotely programmed in minutes, or interrogated at any time, over the segment using a standard PROFIBUS PA configuration tool (such as Siemens SIMATIC PDM). Examples of programmable parameters include:

- **Identification Information**—Manufacturer, product designation/part number, serial number, tag, descriptor, software/hardware revision, installation date, Slave address and PROFIBUS identification number.

- **Input/Output Type and Ranges**—Sensor type, span and zero values, lower/upper output ranges and alarm output status.
- **Adjust Sensor Trim Offset**—Set an offset to compensate for measurement errors that are caused when a temperature sensor is not performing to its rated curve specifications.
- **Set Damping Time**—Eliminate imprecise readings caused by noise and other insignificant process fluctuations by setting a damping time between 1-30 seconds.
- **View Real-Time Process Values**—View the existing process value (in the appropriate engineering unit), and lower and upper range values as a percentage of output span.
- **Choose Sensor Failure Mode**—If the input is lost, you have the choice of the digital output going to a selectable failsafe value, hold last valid value, or the TPZ displaying the PROFIBUS “Wrong” value, which indicates the instrument’s status as “Bad”.

**Figure 2.** The TPZ transmitter’s data and configuration can be viewed, tested and changed from the control room from a DCS or AMS equipped with a standard PROFIBUS PA configuration tool.

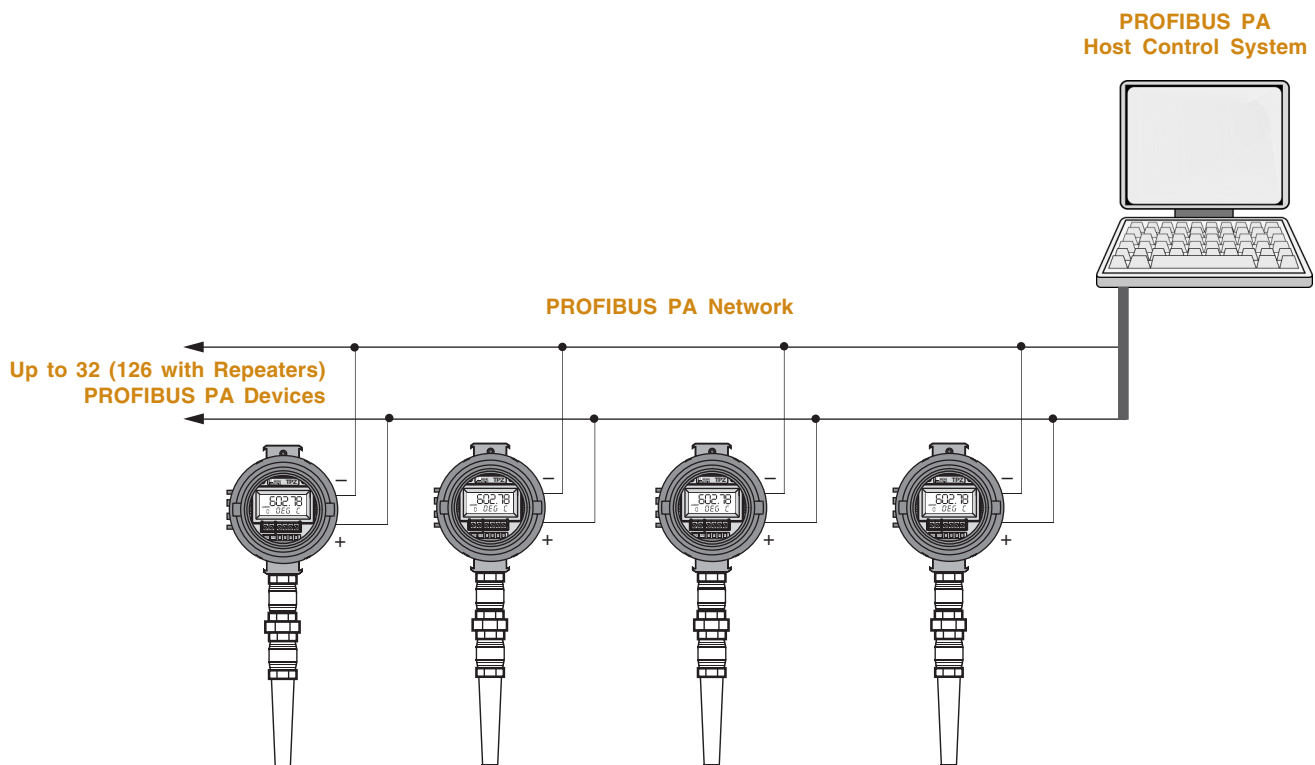

## Total Sensor Diagnostics

TPZ transmitters perform continuous sensor diagnostics. This patented Moore Industries feature can save you from costly lost production time and hours of troubleshooting. If the sensor breaks or otherwise stops sending a signal during operation, the transmitter instantly displays the type and location of the error on its display. Standard programming through the PROFIBUS configuration tool permits configuration of output response in the event of a sensor input failure, including user-selected value and last out value.

## Trims to Respond to Specific Sensor Curve Segments

Most transmitters zero and span values can be calibrated to measure a specific range within a sensor's overall curve capability. However, for even greater measurement accuracy, our transmitter's trim capabilities go much further.

The TPZ can be trimmed with two data points within the selected zero and span measurement range. This advantage allows a complete process range to be monitored, while placing measurement emphasis on a specific segment of the range most critical to the process.

In Figure 3, the actual sensor curve is used in place of the ideal RTD curve between 20°C and 27°C. This provides incredible precision over a limited portion of span, while measuring the remainder of the span with the TPZ's usual outstanding accuracy.

**Figure 3.** The TPZ can be set to measure the segment most critical to the process.

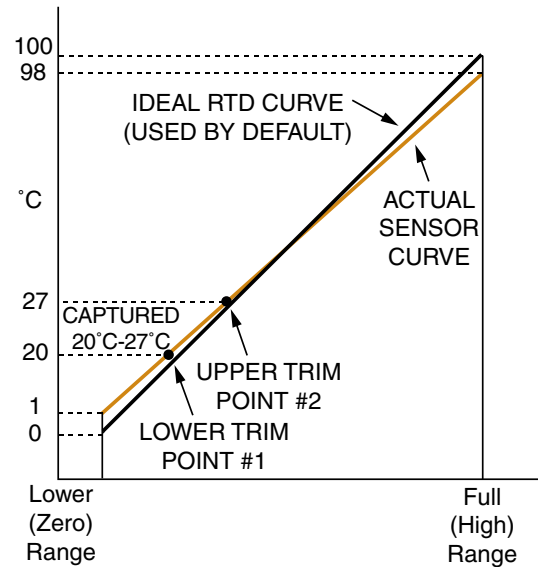

## Precise Linearization and RJC

The TPZ use an advanced linearization method to minimize conformance error. Its Reference (Cold) Junction Compensation techniques produce stable readings even in fluctuating ambient temperature conditions. For non-linear inputs, create custom linearization curves using our PC Configuration Software.

# TPZ

## Programmable PROFIBUS PA Temperature Transmitter

### Specifications

**Performance** **Input Accuracy:** Refer to Table 2  
**Overall Accuracy:** The overall accuracy of the unit is the input accuracy. It includes the combined effects of linearity, hysteresis, repeatability and adjustment resolution. It does not include ambient temperature effect. For T/C input, add the RJC error.  
**Reference Junction Compensation:**  $\pm 0.45^{\circ}\text{C}$  ( $\pm 0.81^{\circ}\text{F}$ )  
**Stability:** Refer to Table 1  
**Isolation:** 500Vrms between input, output and case continuous, and will withstand a 500Vac dielectric strength test for one minute (with no breakdown)  
**Step Response Time:** 500msec, maximum, from the time an input is applied until the time the corresponding floating point processed variable is available to be read by other PROFIBUS devices  
**Over-voltage Protection:** Input,  $\pm 5\text{Vdc}$  peak, maximum  
**Digital Input Filter:** 50/60Hz (user-selectable via the DDL)  
**Power Supply Requirement:** 9-32Vdc, 10.5mA typical; 12.07mA maximum under normal operation; 18mA maximum under fault condition; 9-28V I.S.

**Performance (Continued)** **Power Supply Effect:**  $\pm 0.002\%$  of span per 1V change  
**Load Effect:** N/A  
**T/C Input Impedance:** 40Mohms, nominal  
**Excitation Current:** RTD & Ohms, 250 microamps,  $\pm 10\%$   
**RTD Lead Wire Resistance Maximum:** RTD resistance + 2X lead wire resistance  
 $< 4000$  ohms; Recommended lead wire resistance for three wire connections:  $< 35$  ohms/wire; 10 ohm copper sensor  $< 5$  ohms  
**Sensor Lead Resistance Effect:** 1.0 ohm in reading/ohm of lead resistance for 2-wire sensors; 1.0 ohm in reading/ohm of lead of unbalanced resistance for 3-wire sensors; no effect on 4-wire sensors  
**Resolution:** Input, 20-bit

**Display Type:** Top Row, 10mm (0.4 in) high black digits on a reflective background; Bottom Row, 6mm (0.225 in) high digits on a reflective background; Two-digit PROFIBUS address indicator  
**Format:** Two rows of five alphanumeric characters

**Display (Continued)** **Decimal Points:** Automatically adjusting decimal point with a two decimal-place maximum  
**Range:** -99999 to 99999  
**Minimum Display Span:** 1.00

**Ambient Temperature** **Operating & Storage Range:**  $-40^{\circ}\text{C}$  to  $+85^{\circ}\text{C}$  ( $-40^{\circ}\text{F}$  to  $+185^{\circ}\text{F}$ )  
**Relative Humidity:** 0-95%, non-condensing  
**Ambient Temperature Effect:**  $\pm 0.003\%$  of maximum span/ $^{\circ}\text{C}$  change in ambient temperature  
**Effect on Reference Junction Compensation:**  $\pm 0.005^{\circ}\text{C}$  of input span/ $^{\circ}\text{C}$  change of ambient temperature  
**RF/EMI Immunity:** 20V/m@80-1000MHz, 1kHz AM when tested according to IEC 1000-4-3-1995  
**Startup Time:** Performance falls within specification 8 seconds after power is applied  
**Noise Rejection:** Common mode, 100dB@50/60Hz; Normal Mode: 70dB typical at 200mVp-p@50/60Hz

**Weight** 235g (833 oz)

Table 1. Long-Term Stability

Stability (% of maximum span)	Input to PROFIBUS		
	1 yr	3 yrs	5 yrs
T/C, mV	0.008	0.014	0.019
RTD, Ohm, Potentiometer	0.047	0.081	0.104

**Table 2.** Input and Accuracy

Input	Type	$\alpha^*$	Ohms	Conformance Range	Minimum Span	Input Accuracy	Maximum Range	Sensor-to-Transmitter Matching
RTD (2-, 3-, 4-Wire)	Platinum	0.003850	100	-200 to 850°C -328 to 1562°F	10°C (18°F)	±0.1°C (±0.18°F)	-240 to 960°C -400 to 1760°F	Up to ±0.014°C (±0.025°F) system accuracy*.
			200					
			300					
			400					
			500					
		1000						
		0.003902	100	-100 to 650°C -148 to 1202°F			-240 to 580°C -400 to 1076°F	
			200					
			400					
			500					
1000								
0.003916	100	-200 to 510°C -328 to 950°F	-240 to 580°C -400 to 1076°F					
Nickel	0.00672	120	-80 to 320°C -112 to 608°F	-100 to 360°C -148 to 680°F				
Copper	0.00427	9.035	-50 to 250°C -58 to 482°F	±0.85°C (±1.53°F)	-65 to 280°C -85 to 536°F			
Ohms	Direct Resistance	n/a	0-4000 ohms	0-4000 ohms	10 ohms	±0.4 ohms	0-4000 ohms	
	Potentiometer		4000 ohms	0-100%	10%	±0.1%	0-100%	
T/C	J	n/a	n/a	-180 to 760°C -292 to 1400°F	35°C 63°F	±0.25°C (±0.45°F)	-210 to 770°C -346 to 1418°F	
	K	n/a	n/a	-150 to 1370°C -238 to 2498°F	40°C 72°F	±0.3°C (±0.54°F)	-270 to 1390°C -454 to 2534°F	
	E	n/a	n/a	-170 to 1000°C -274 to 1832°F	35°C 63°F	±0.2°C (±0.36°F)	-270 to 1013°C -454 to 1855.4°F	
	T	n/a	n/a	-170 to 400°C -274 to 752°F	35°C 63°F	±0.25°C (±0.45°F)	-270 to 407°C -454 to 764.6°F	
	R	n/a	n/a	0 to 1760°C 32 to 3200°F	50°C 90°F	±0.55°C (±0.99°F)	-50 to 1786°C -58 to 3246.8°F	
	S	n/a	n/a	0 to 1760°C 32 to 3200°F	50°C 90°F	±0.55°C (±0.99°F)	-50 to 1786°C -58 to 3246.8°F	
	B	n/a	n/a	400 to 1820°C 752 to 3308°F	75°C 135°F	±0.75°C (±1.35°F)	200 to 1836°C 392 to 3336.8°F	
	N	n/a	n/a	-130 to 1300°C -202 to 2372°F	45°C 81°F	±0.4°C (±0.72°F)	-270 to 1316°C -454 to 2400.8°F	
	C	n/a	n/a	0 to 2300°C 32 to 4172°F	100°C 180°F	±0.8°C (±1.44°F)	0 to 2338°C 32 to 4240.4°F	
mV	DC	n/a	n/a	-50 to 1000mV	4mV	15 microvolts	-50 to 1000mV	

\*High-accuracy measurements are achieved by using a 4-wire, 1000 ohm platinum RTD with a span of 100°F (50°F minimum) calibrated in our sensor-matching calibration bath. Contact our factory for additional information.

# TPZ

## Programmable PROFIBUS PA Temperature Transmitter

### Ordering Information

Unit	Input	Output	Power	Options	Housing
<b>TPZ</b> Programmable PROFIBUS PA Transmitter	<b>TPRG</b> Programs to accept RTD, T/C, ohm and mV inputs	<b>PA</b> PROFIBUS PA	<b>9-32DC</b> , 10.5mA typical; 12.07mA maximum; 18mA maximum under fault condition	None Available	<b>HP</b> Hockey puck housing and spring clips <b>DN</b> Snap-in mounting for HP case on TS-32 DIN-rail <b>FL</b> Mounting flanges on HP for relay track or screw mounting <b>FLD</b> Mounting flanges on HP for 3½" relay track mounting <b>BH2NG</b> Explosion-Proof enclosure with two 1/2-inch NPT entry ports and a glass cover <b>BH2TG</b> Explosion-Proof enclosure with two 3/4-inch NPT entry ports and a glass cover <b>BH2MG</b> Explosion-Proof enclosure with two M20 x 1.5 NPT entry ports and a glass cover <b>BH3NG</b> Explosion-Proof enclosure with three 1/2-inch NPT entry ports <b>BH3TG</b> Explosion-Proof enclosure with two 3/4-inch side-entry NPT ports, one 1/2" bottom port, and a glass cover <b>BH3MG</b> Explosion-Proof enclosure with two, M20 x 1.5 side-entry ports, one 1/2" bottom-entry port, and a glass cover <b>D2LC</b> 2-Hub, low base, clear cover, IP66/NEMA 4X enclosure <b>SB2NG</b> 2-Hub, Explosion-Proof enclosure with two, ½-inch NPT entry ports and a glass cover <b>SB2MG</b> 2-Hub, Explosion-Proof enclosure with two, M20 x 1.5 entry ports and a glass cover  P suffix indicates enclosure is equipped with 2" pipe-mount hardware kit (BH2NGP)

To order, specify: Unit / Input / Output / Power / Options [Housing]

Model number example: TPZ / TPRG / PA / 9-32DC [BH2NG]

### Everything You Need is Included...

Each TPZ order comes with one copy of our Intelligent Configuration Software (Windows® compatible) on CD and one non-isolated configuration cable FREE of charge.

To order additional software or cables:

Part Number	Part
<b>750-75E05-01</b>	Intelligent PC Configuration Software
<b>803-039-26</b>	Isolated Configuration Cable
<b>803-040-26</b>	Non-Isolated Configuration Cable

Figure 4. Sensor/input connections

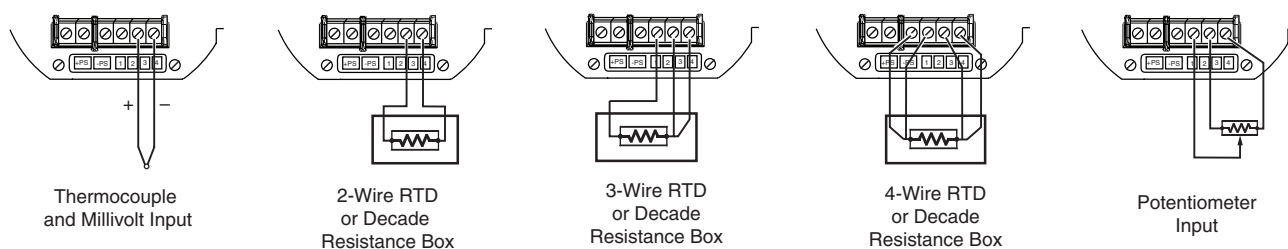

**Figure 5.** Dimensions for TPZ in HP (hockey-puck) housing with flanges (FL)

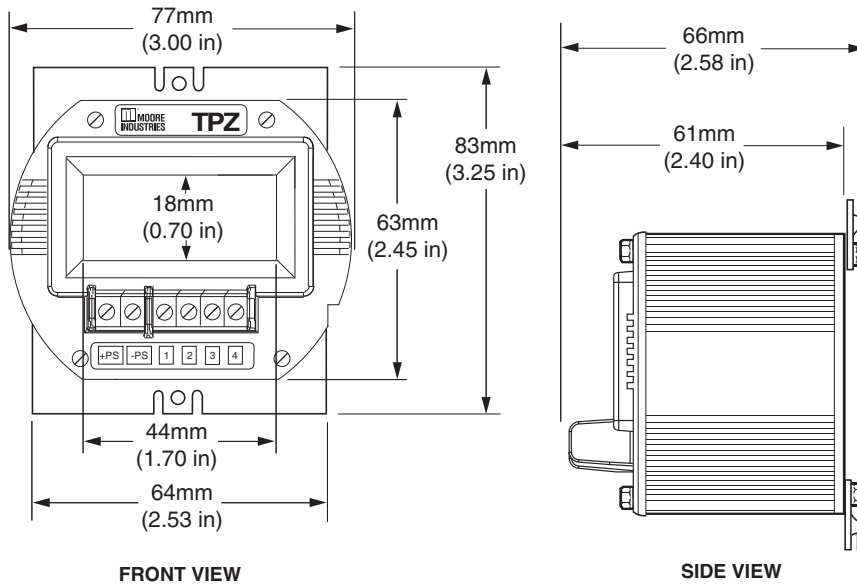

**Figure 6.** Dimensions for the TPZ in BH field-mount enclosure

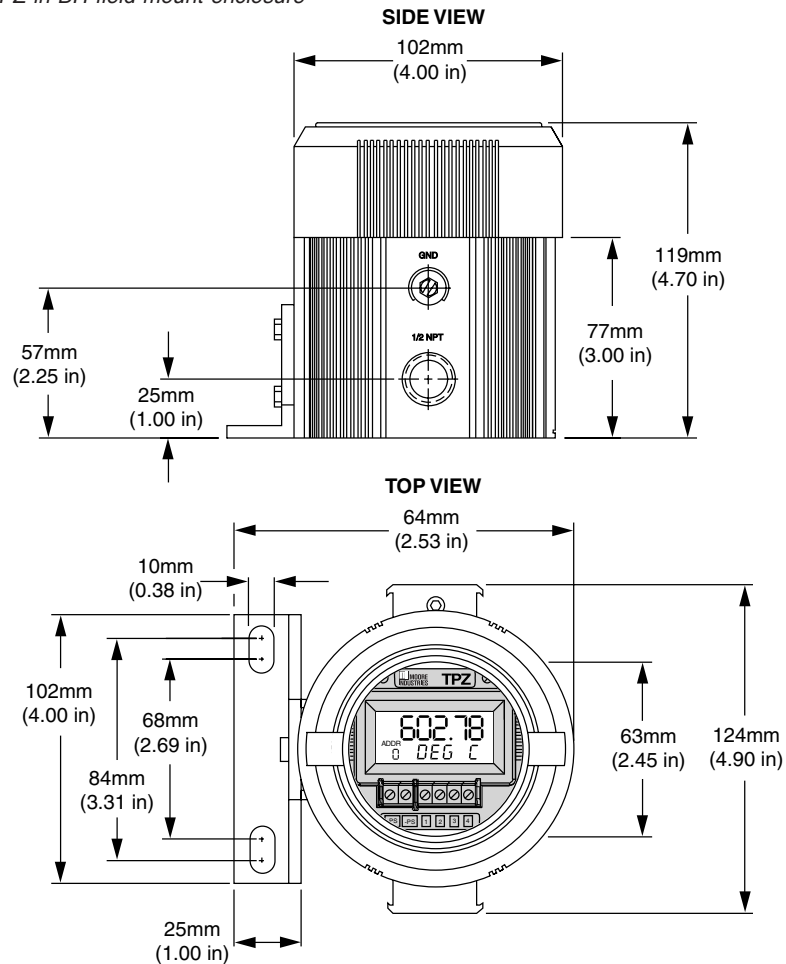

# TPZ

## Programmable PROFIBUS PA Temperature Transmitter

Figure 7. Dimensions for TPZ in D-BOX field-mount enclosure

