

Description

Moore Industries' SDY PC-Programmable Signal Isolator/Converter with Display combines smart digital technology with a large display to deliver an accurate signal that is easily monitored in the field.

The highly versatile SDY accepts a wide range of current or voltage inputs, then outputs the signal as an isolated, proportional, 4-20mA current. A flexible analog/digital hybrid, this 2-wire (loop-powered) transmitter programs in seconds to handle a wide range of signal interface applications:

- **Monitor Signals** using its large, accurate display.
- **Isolate Signals** to stop erratic process measurements caused by ground loops.
- **Convert Signals** so field instruments can interface directly with an indicator, recorder, DCS, PLC or PC-based SCADA system.
- **Divert Signals** so the output from one transmitter can be sent to two separate locations.
- **Protect Equipment and Signals** by eliminating common electrical paths.
- **Boost Signals** so that more instruments can be added to an overburdened loop.
- **Solve "Bucking Power Supplies"** by stopping the conflict caused when a 4-wire transmitter and a DCS both power the same process loop.

Figure 1. Program the versatile SDY to accept any one of a wide range of inputs and convert the input into the EGU of your choice.

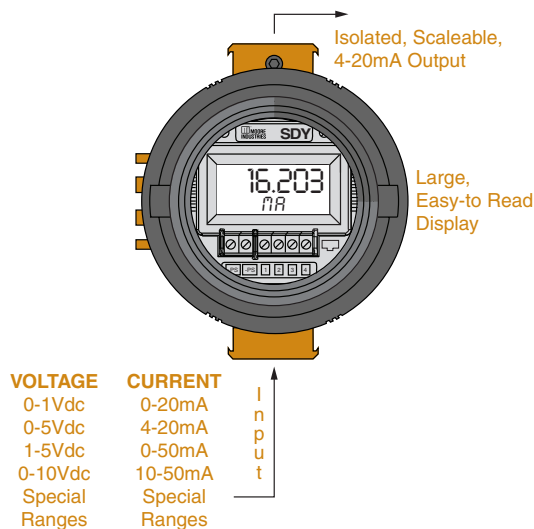

Available in explosion-proof enclosures and a variety of other configurations, the SDY installs easily in even the most rugged environments.

Features

- **Wide range of signal input choices.** There's no need to specify and stock fixed-range instruments as spares. The SDY handles the majority of current/voltage interface applications you are likely to encounter.
- **Custom linearization curves.** Easily create your own custom linearization curve tables to accurately convert any non-linear input signals to their linear representations.
- **Easy-to-read, customizable display.** The SDY's display features two rows of large characters that can be set to display any EGU.
- **Input/output opto isolation.** The SDY delivers superior protection against the harmful effects of ground loops and other plant "noise".
- **RFI/EMI protection.** The SDY is resistant to the harmful, unpredictable effects of radio frequency and electromagnetic interference.
- **Enhanced configuration software.** From a single screen, you can set all the application-specific parameters.

Certifications



Specifications

<p>Performance</p> <p>Overall Accuracy: ±0.036% of span (includes input accuracy, output accuracy, and the combined effects of linearity, hysteresis, repeatability and adjustment resolution)</p> <p>Stability: Input to output stability (% of span): 1 year: 0.09%; 3 years: 0.15%; 5 years: 0.20%</p> <p>Minimum Input Span: Current, 1.0mA; Voltage, 250mV</p> <p>Isolation: 500Vac/1000Vdc input to output to case</p> <p>Measurement Cycle: Updates 8 times per second</p> <p>Response Time: 128msec from time input is applied until output settles to the specified output accuracy</p> <p>Step Response: 128msec maximum for the output to change from 10% to 90% of its scale for an input step change of 0% to 100%</p> <p>Input Impedance: Voltage, 1Mohms; Current, 20 ohms</p> <p>Load Effect: Negligible within specified load limits</p>	<p>Performance (continued)</p> <p>Ripple: 10mVpp, maximum (measured across 250 ohm resistor)</p> <p>Power Supply Effect: 0.002% of span per 1V change</p> <p>Over-Voltage Protection: 48V, maximum on output; 48V reverse polarity protection on output</p> <p>Maximum Input Overrange: Current: 100mA maximum continuous; Voltage on Current Input: ±1.5Vdc peak; Voltage: 18Vdc</p> <p>Load Capability: $\frac{\text{Supply Voltage} - 10V}{0.024A} = \text{Ohms}$</p> <p>Output Current Limiting: 3.8mA (low) and 21.4mA (high)</p> <p>Display Type: LCD: Top Row, 10.16mm (0.4 in) high black digits on a reflective background; Bottom Row, 5.72mm (0.225 in) high black digits on a reflective background</p> <p>Format: Two rows of five alphanumeric characters</p> <p>Range: -99999 to 99999</p> <p>Minimum Display Span: 1.00</p>	<p>Ambient Conditions</p> <p>Operating Range: Transmitter: -40°C to +85°C (-40°F to +185°F) Display: -25°C to +85°C (-13°F to +185°F)</p> <p>Storage Range: -40°C to +85°C (-40°F to +185°F)</p> <p>Effect of Ambient Temperature on Accuracy: ±0.015% of span/°C</p> <p>Relative Humidity: 0-95%, non-condensing</p> <p>RFI/EMI Immunity: 20V/m @ 20-1000MHz, when tested according to SAMA standard 33.1 abc; 20V/m @ 20-100MHz, 1kHz AM @ 80% when tested according to IEC 1000-4-3-1995 with <0.5% error</p> <p>Common Mode Rejection: 100dB, minimum, @ 50/60Hz</p> <p>Normal Mode Rejection: 60dB, typical, @ 1Vp-p, 50/60Hz</p> <p>Weight</p> <p>HP Housing: 178g (6.3 oz)</p> <p>BH Housing: 1.5kg (3.3 lbs)</p> <p>D-BOX Housing: 688g (1 lb, 8.3 oz)</p>
---	---	---

Rugged Enclosures Available

We carry a complete line of durable enclosures to protect and complement our high-quality isolators. Choose from our explosion-proof BH housing or our NEMA 4X and IP66 certified D-BOX housing.

Everything You Need is Included...

Each SDY order comes with one copy of our Intelligent PC Configuration Software (Windows® compatible) and one non-isolated configuration cable.

To order additional software or cables:

Part Number	Part
750-75E05-01	Intelligent PC Configuration Software
803-039-26	Isolated Configuration Cable
803-040-26	Non-Isolated Configuration Cable

Ordering Information

Unit	Input	Output	Power	Options	Housings
SDY PC-Program- mable Isolator/ Converter with Display	PRG Programmable with supplied Configuration Software <u>CURRENT (into 20 ohms)</u> Any range from -2.5mA to 55mA including: 0-20mA 4-20mA 0-50mA 10-50mA <u>VOLTAGE (into 1Mohm)</u> Any range from -0.5V to 11V including: 0-1Vdc 0-5Vdc 1-5Vdc 0-10Vdc (recommended minimum span, 250mV)	4-20MA User scaleable with supplied software	10-42DC 10-30DC for -ISC, -ISF, -ISE and -NE options	-ISC CSA approved IS -ISF FM approved IS -ISE ATEX IS approved -NE ATEX Type N approved with BH	BH2NG 2-Hub, explosion-proof enclosure with glass cover BH3NG 3-Hub, explosion-proof enclosure with glass cover D1LC 1-Hub, low base, clear cover, NEMA 4X (IP66) enclosure D2LC 2-Hub, low base, clear cover, NEMA 4X (IP66) enclosure HP Hockey-puck housing and spring clips DN Snap-in mounting for HP case on TS-32 DIN rail FL Mounting flanges on HP suitable for relay track or screw mounting FLD Mounting flanges on HP suitable for 3½" relay track or screw mounting SB2NG 2-Hub, Explosion-Proof enclosure with two, ½-inch NPT entry ports and a glass cover SB2MG 2-Hub, Explosion-Proof enclosure with two, M20 x 1.5 entry ports and a glass cover A suffix indicates SAA/TestSafe (Ex d) Flame-Proof approvals (i.e. BH2NGA) E suffix indicates ATEX (EEx d) Flame-Proof approvals (i.e. BH2NGE) P suffix indicates enclosure comes equipped with base plate and U-bolts for mounting on a 2-inch pipe (i.e. BH2NGP or SB2MGP)

To order, specify: Unit / Input / Output / Power [Housing]
 Model Number Example: SDY / PRG / 4-20MA / 10-42DC [BH2NG]

Certifications



Factory Mutual Approvals – FM Global

[HP in BH and SB Housings]

Explosion-Proof*

Class I, Division 1, Groups A*, B, C, D.

Dust-Ignition Proof –

Class II & III, Division 1, Groups E, F, G.

NEMA 4X; IP66; T6 @ 60°C_{Max. Amb.}

SDY [HP]

Intrinsically Safe –

Class I, II, III, Division 1, Groups A, B, C, D.

Non-Incendive –

Class I, Division 2, Groups A, B, C, D.

Suitable For: Class II, Division 2, Groups F, G.

Class III, Division 2.

T4A@60°C / T5@40°C Max. Amb. Temp.



Canadian Standards Association (CSA)

General (Ordinary) Locations

Intrinsically Safe – [HP]:

Class I, Division 1 & 2, Groups A, B, C, D.

T4A@60°C / T5@40°C Max. Amb. Temp.



SAA TestSafe (Australian) Approvals:

Flame-Proof [HP in BH Housing]

Ex d IIC T6@60°C



European Approvals:

CENELEC/ATEX Directive 94/9/EC

[HP in BH Housing]

Intrinsically Safe – II 1G EEx ia IIC T4

Type N – II 3G EEx nA II T4

T4@60°C Maximum Ambient Temperature

Flame-Proof II 2GD EEx d IIC

T6@60°C Maximum Ambient Temperature



CE Conformant – EMC Directive 89/336/EEC

EN 61326

*BH Housing–Group A only: Seal all conduits within 18".

SDY

PC-Programmable
Signal Isolator/Converter with Display

Additional Features

Custom Linearization Curves

Program your SDY with up to 85 custom linearization points. The ability to plot a custom linearization curve is beneficial when non-linear input signals must be converted to linear output representations. Typical applications include monitoring a non-linear transducer, the level of odd-shaped tanks and flow meter linearization.

Monitor Signals

Let the SDY make checking the loop easy with its accurate current transmission and large display. And, with an update rate of eight times per second, you can be confident that the display precisely reflects the loop's status.

Customized Display

The versatile SDY can be programmed to display the input, output or toggle between both. It will also display the engineering unit of your choice (up to five capital letters).

Long-Term Stability

With error rates as low as $\pm 0.09\%$ over a one year period, and $\pm 0.20\%$ for five years, you can schedule calibrations less frequently without sacrificing accuracy.

Powerful Isolation

Continuous isolation of 500Vac/1000Vdc input to output to case will prevent false signals due to ground loops and other noise.

Advanced Noise Rejection

Filter out 50 or 60Hz noise with our noise rejection feature.

Certified Field Enclosures Available

Order the SDY in our durable BH enclosure for explosion-proof protection at an affordable price. For applications in rugged environments where explosion-proof protection is not required, choose the NEMA 4X and IP66 certified D-BOX housing.

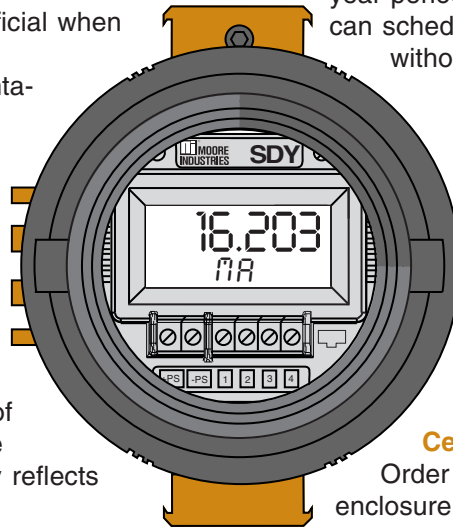

Convert Signals

The SDY takes one process signal type (such as 1-5V) and converts it to a standard, isolated 4-20mA. This allows devices like transmitters and transducers to interface directly with an indicator, recorder, DCS, PLC, or PC-based SCADA system.

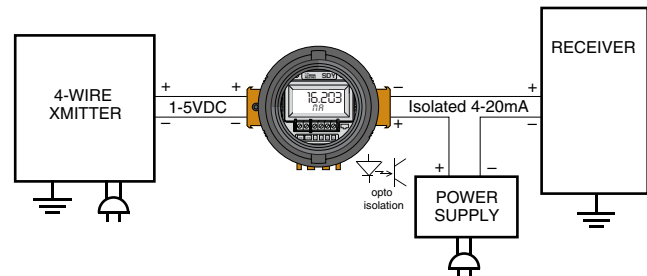

Solve "Bucking Power Supplies"

When two devices (such as a 4-wire transmitter and a DCS) are trying to source power to a loop, the result is a non-functioning loop. When neither of the devices can be eliminated, the solution is the SDY. It can operate with powered inputs from both sides, thus restoring normal operations to the loop.

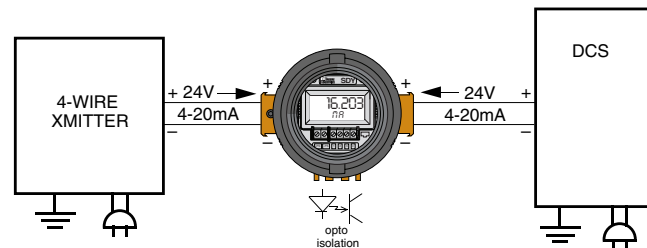

Stop Ground Noise

A difference in potential between a grounded transmitter and a grounded receiving device on the same loop may result in unpredictable ground loop problems, which can lead to signal drift.

Use the SDY to break the galvanic path between a field transmitter and an indicator, recorder, DCS, PLC or PC-based SCADA system. This stops the harmful effects of ground loops, motor noise and other electrical interferences.

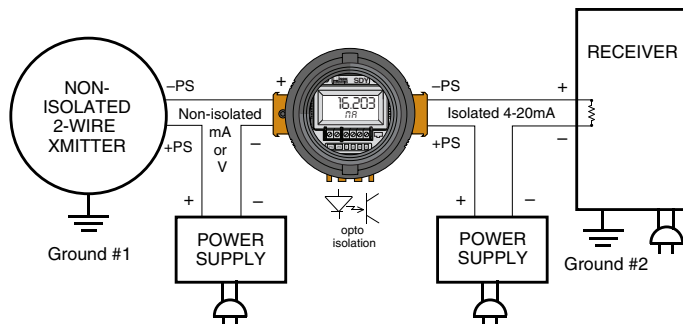

Boost Signals

If you need to add another instrument to an overloaded loop, use the SDY. It features a high drive capability of 600 ohms (with a 24V power supply) and an input impedance of just 20 ohms.

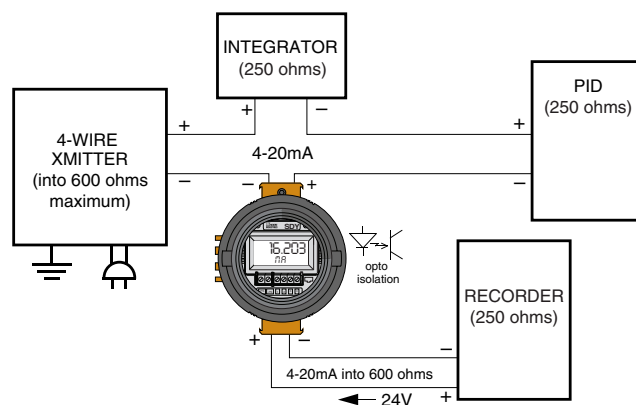

Divert and Protect Signals

Using the SDY, you can send the output from one transmitter to a second location, protect expensive monitoring/control equipment by eliminating common electrical paths, or create a buffer between devices to allow interruption of one system without impacting the other.

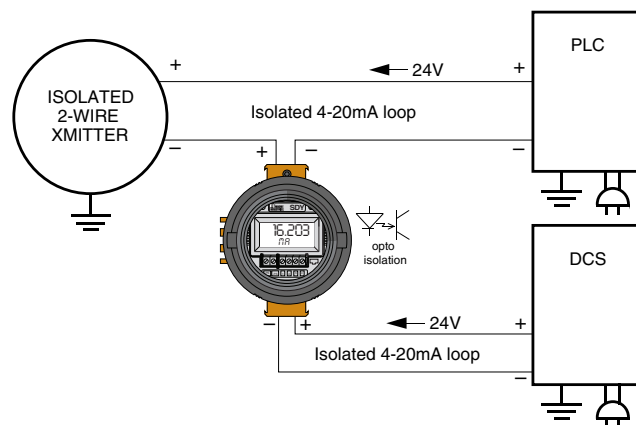

SDY

PC-Programmable
Signal Isolator/Converter with Display

One Window. One Minute. One Setup.

Configuring the SDY is as simple as point-and-click. All you need is a PC running Windows®, our Configuration Software (one copy supplied free with each order), and a configuration cable. In minutes, you can begin configuring your transmitter's:

- Input type and range (zero and full scale)
- Output range (4-20mA, zero and full scale)
- Noise rejection (50Hz or 60Hz)
- Direct or reverse output
- Over or under input range detection
- Custom instrument tag and serial number
- Custom input linearization
- Custom input trimming
- Fixed output with an easy loop test
- Damping time for erratic signal compensation (0-20 seconds)

Custom Linearization Tables—Unusual inputs are not a problem for the SDY. Not when it is so easy to build a custom 85-point linearization table with the Configuration Program's straightforward interface.

Output Damping—If your sensor is prone to step increases and decreases, use the SDY to lessen the impact on your process. You can program a damping value from 0 to 20 seconds, averaging out sensor fluctuations over the time period setting, and lessening the impact of step changes.

On-Screen Setup Confirmation—Once programmed, the operating parameters you have selected are constantly displayed in the configuration window.

Figure 2. Program the SDY in a minute or less using just this software window.

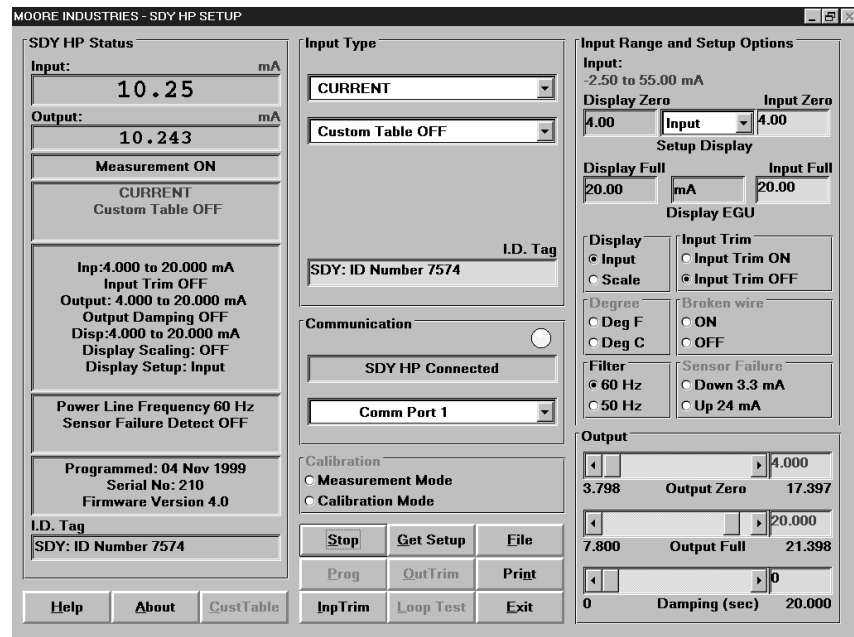

Configuration Alerts—Data fields on the configuration window provide alert messages (such as “Zero or Full Scale Outside of Conformance Range”) to let you know when you are making a nonstandard or ill-advised selection.

Store and Print Files—After you've created a configuration file, it can be downloaded to multiple SDYs, printed out as a hardcopy, or named and stored (on a PC hard drive or other media).

Reverse Output—Setting Zero Scale Input numerically above Full Scale Input will result in the transmitter's output going up when the input goes down, and vice-versa. When you have chosen this operation, the “Output” portion of the configuration screen changes to read “Reverse Output”.

Digital Output Trimming—A sophisticated yet simple-to-implement software feature allows you to adjust the SDY's output to compensate for inaccuracies in your readout equipment. The “Zero Scale Output” can be adjusted between 3.797 and 17.400mA. The “Full Scale Output” adjusts between 7.798 and 21.401mA.

Context-Sensitive HELP System—Just click on Help, then on the area on the Configuration Screen where you are encountering difficulty, and a concise explanation appears.

Figure 3. Dimensions of the SDY in a D-BOX Enclosure

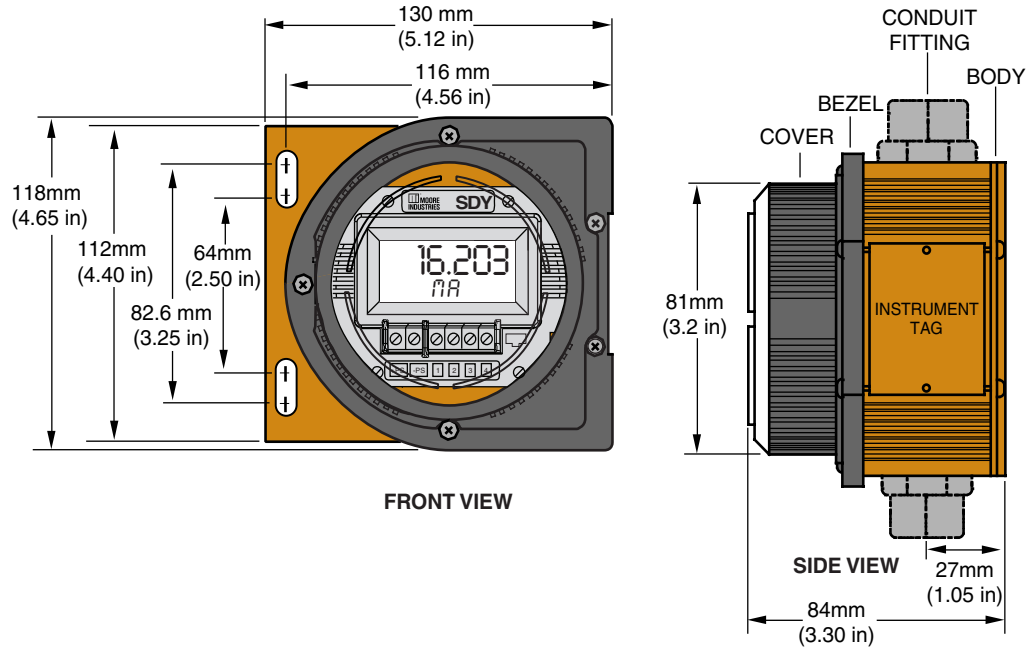
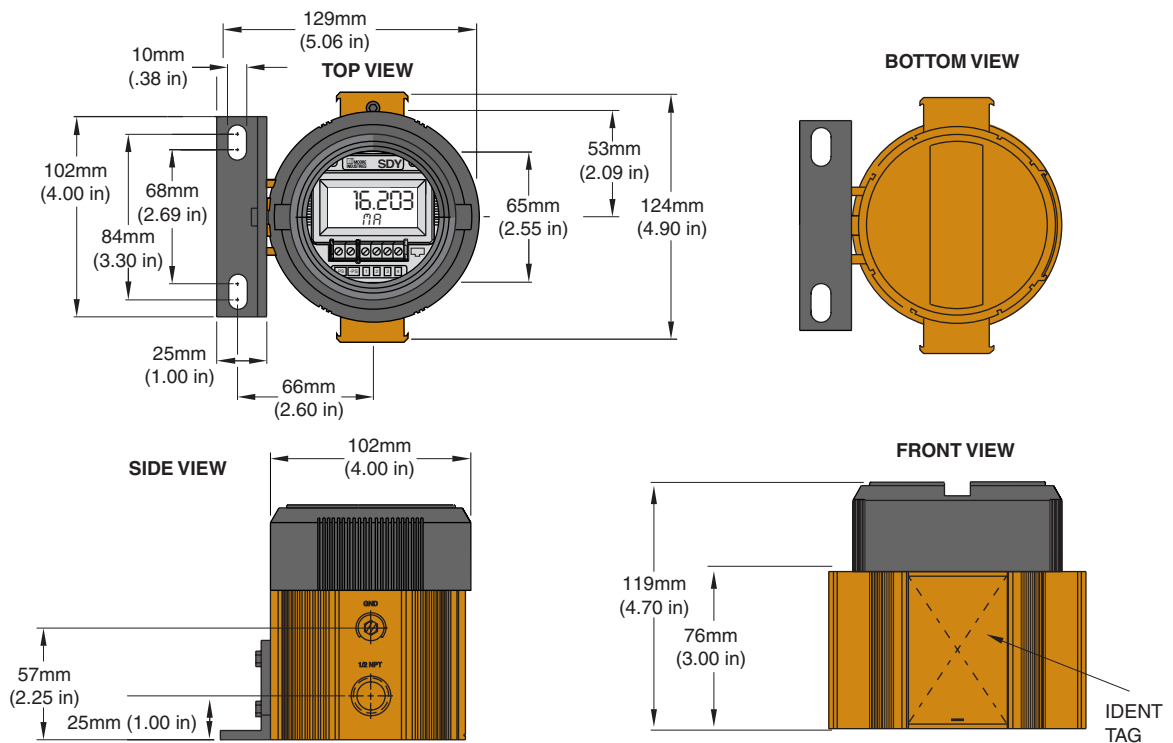

Figure 4. Dimensions of the SDY in a BH Enclosure



SDY

PC-Programmable
Signal Isolator/Converter With Display

Figure 5. Dimensions of SDY Hockey-Puck with Flange Mount

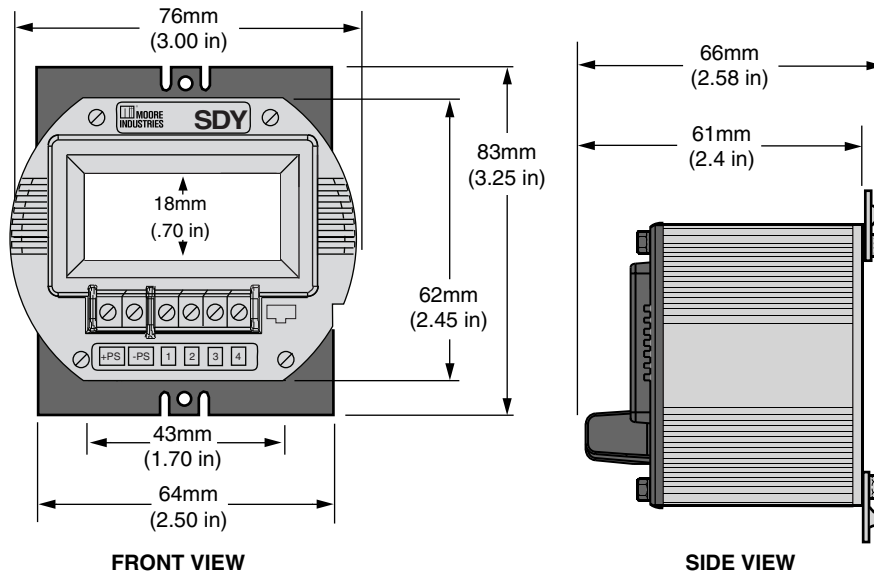

Table 1. Terminal Designations.

Input Type	Input Terminals				Output Terminals	
	1	2	3	4	Left to Right	
Current Inputs		+I		-I	+PS	-PS
Voltage Inputs			+V	-V	+PS	-PS



WORLDWIDE • www.miinet.com

United States • info@miinet.com
Tel: (818) 894-7111 • FAX: (818) 891-2816
Australia • sales@mooreind.com.au
Tel: (02) 8536-7200 • FAX: (02) 9525-7296

Belgium • info@mooreind.be
Tel: 03/448.10.18 • FAX: 03/440.17.97
The Netherlands • sales@mooreind.nl
Tel: (0)344-617971 • FAX: (0)344-615920

China • sales@mooreind.sh.cn
Tel: 86-21-62491499 • FAX: 86-21-62490635
United Kingdom • sales@mooreind.com
Tel: 01293 514488 • FAX: 01293 536852